

Q1.Figure 1 shows photographs of some animal cells at different stages during the cell cycle.

Figure 1

A

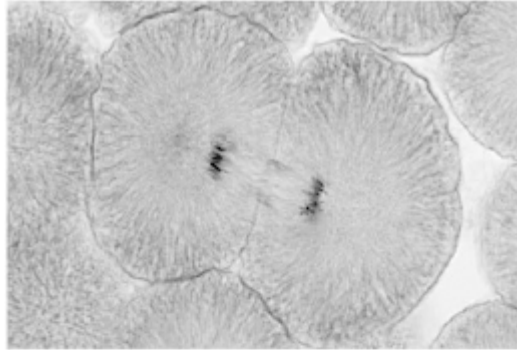

B

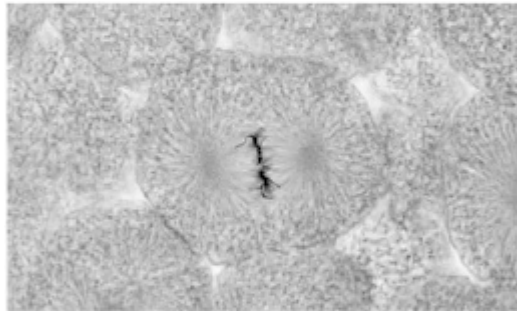

C

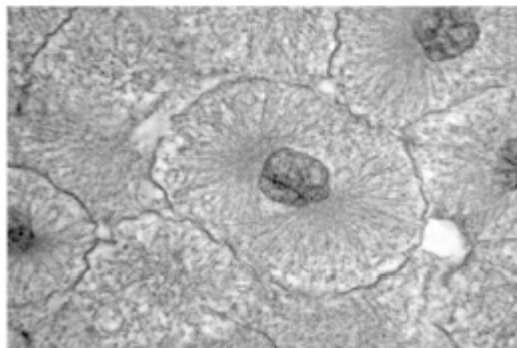

A © Ed Reschke/Photolibary/Getty Images
B © Ed Reschke/Oxford Scientific/Getty Images
C © Ed Reschke/Photolibary/Getty Images

(a) Which photograph in **Figure 1** shows a cell that is **not** going through mitosis?

Tick **one** box.

A

B

C

(1)

(b) Describe what is happening in photograph A.

.....
.....
.....
.....
.....

(2)

(c) A student wanted to find out more about the cell cycle.

The student made a slide of an onion root tip.

She counted the number of cells in each stage of the cell cycle in one field of view.

The table below shows the results.

	Stages in the cell cycle					Total
	Non-dividing cells	Stage 1	Stage 2	Stage 3	Stage 4	
Number of cells	20	9	4	2	1	36

Each stage of the cell cycle takes a different amount of time.

Which stage is the fastest in the cell cycle?

Give a reason for your answer.

Stage

Reason

.....

(2)

(d) The cell cycle in an onion root tip cell takes 16 hours.

Calculate the length of time **Stage 2** lasts in a typical cell.

Give your answer to 2 significant figures.

.....
.....
.....
.....

Time in **Stage 2** = minutes

(3)

(e) Bacteria such as *Escherichia coli* undergo cell division similar to mitosis.

Figure 2 shows a growth curve for *E. coli* grown in a nutrient broth.

Figure 2

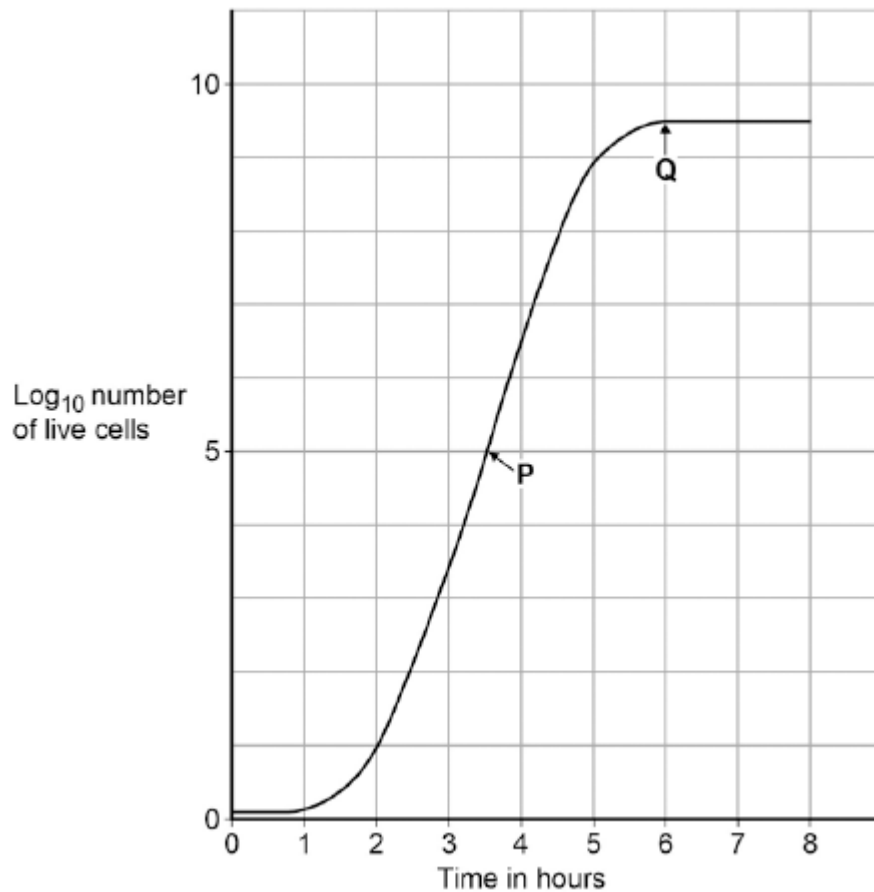

What type of cell division causes the change in number of *E. coli* cells at **P**?

.....

(1)

(f) Suggest why the number of cells levels out at **Q**.

.....

.....

.....

.....

.....

.....

(2)

(Total 11 marks)

Q2. The diagram shows two patterns of cell division. Cell division type **A** is used in gamete formation. Cell division type **B** is used in normal growth.

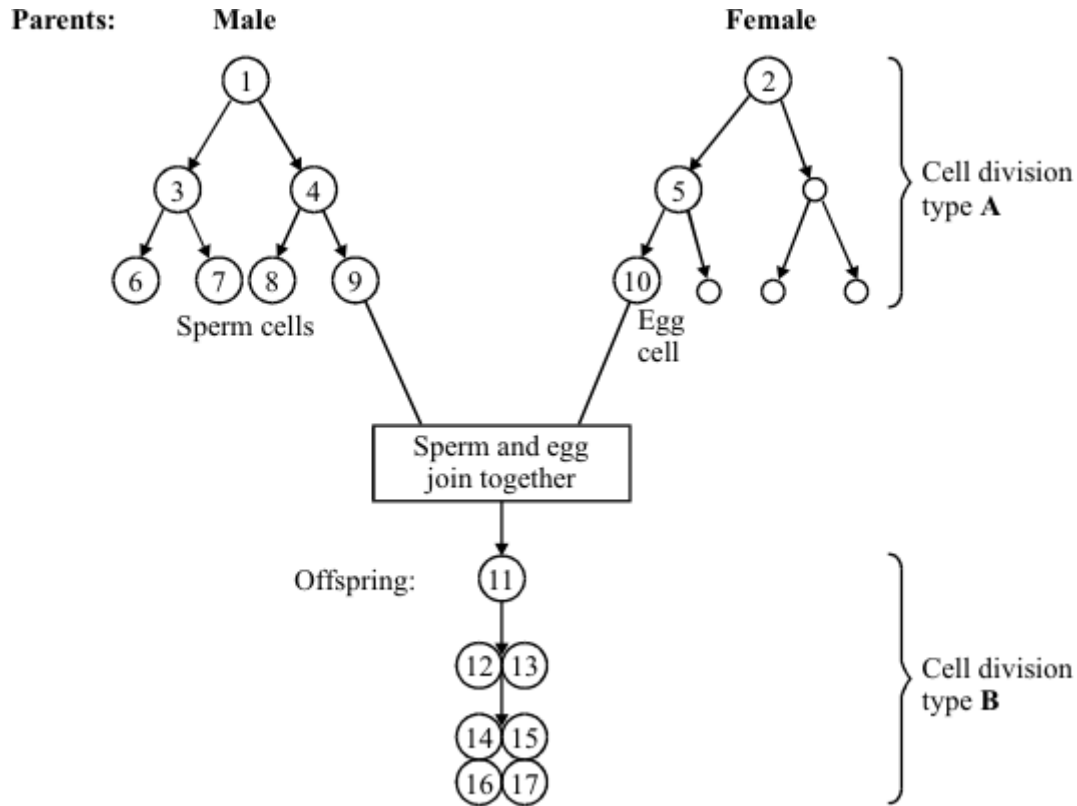

(a) Name the two types of cell division, **A** and **B**, shown in the diagram.

Type **A**

Type **B**

(2)

(b) Name the process in which an egg and sperm join together.

.....

(1)

(c) Cell 1 contains 46 chromosomes. How many chromosomes will there be in:

(i) cell **10**; (1)

(ii) cell **14**?
..... (1)

(Total 5 marks)

Q3. The diagram shows how an immature egg could be used either to produce cells to treat some human diseases or to produce a baby.

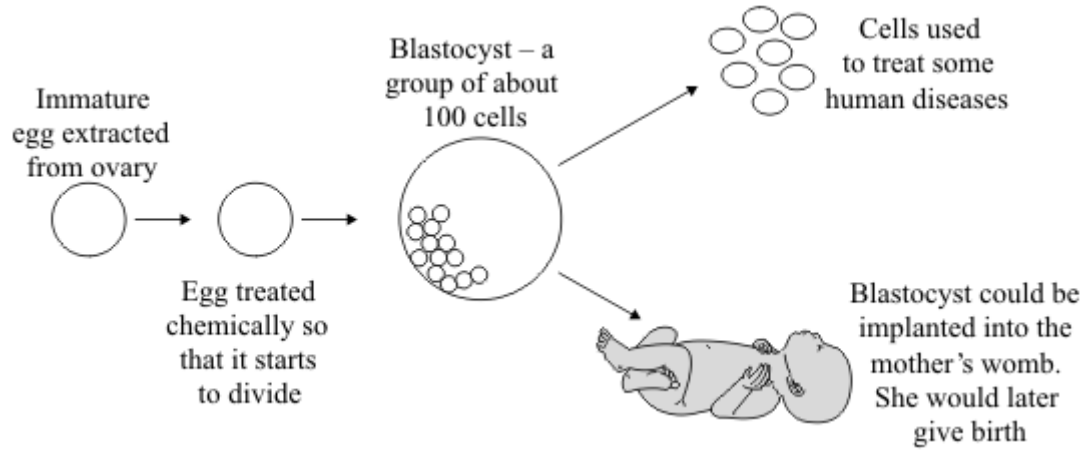

Scientists may be allowed to use this technique to produce cells to treat some human diseases, but not to produce babies.

Using information from the diagram, suggest an explanation for this.

.....

.....

.....

.....

.....

.....

.....

.....

.....

.....

.....

(Total 4 marks)

Q4. Meiosis and mitosis are different types of division in human cells. Compare the two processes by referring to where each takes place and the kind of products that are made.

.....

.....

.....

.....

.....

.....

.....

.....

.....

.....

.....

.....

.....

.....

.....

(Total 6 marks)

Q5. The table shows the number of chromosomes found in each body cell of some different organisms.

Animals		Plants	
Species	Number of chromosomes in each body cell	Species	Number of chromosomes in each body cell
Fruit fly	8	Tomato	24
Goat	60	Potato	44
Human	46	Rice	24

(a) Nearly every organism on earth has an even number of chromosomes in its body cells.

Suggest why.

.....

(1)

(b) Chromosomes contain DNA molecules.

Describe the function of DNA.

.....

(2)

(c) Gametes are made in the testes by meiosis.

(i) Look at the diagrams.

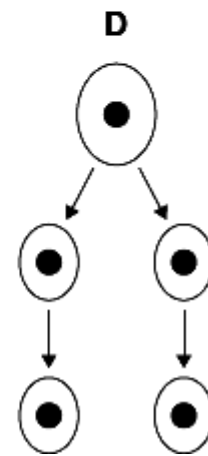
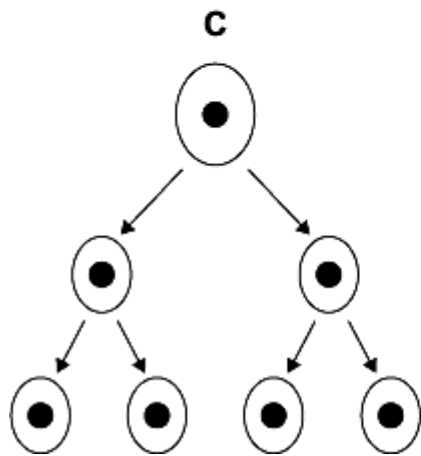
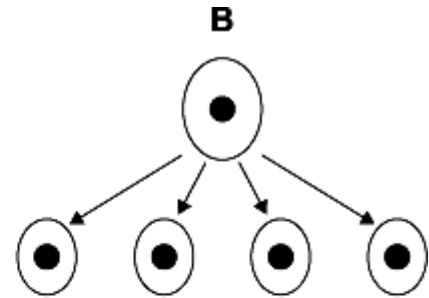
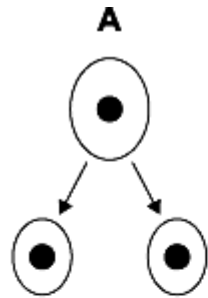

Which diagram, **A**, **B**, **C** or **D**, represents how cell division by meiosis produces

gametes in the testes?

(1)

(ii) How many chromosomes will each goat gamete contain?

.....

(1)

(d) Body cells divide by mitosis.

(i) Why is the ability of body cells to divide important?

.....

.....

(1)

- (ii) When a body cell of a potato plant divides, how many chromosomes will each of the new cells contain?

.....

(1)
(Total 7 marks)

Q6. Read the information about stem cells.

Stem cells are used to treat some human diseases.

Stem cells can be collected from early embryos. These stem cells have not begun to differentiate, so they could be used to produce any kind of cell, tissue or organ. The use of embryonic stem cells to treat human diseases is new and, for some diseases, trials on patients are happening now.

Stem cells can also be collected from adult bone marrow. The operation is simple but may be painful. Stem cells in bone marrow mainly differentiate to form blood cells. These stem cells have been used successfully for many years to treat some kinds of blood disease. Recently there have been trials of other types of stem cell from bone marrow. These stem cells are used to treat diseases such as heart disease.

Evaluate the use of stem cells from embryos or from adult bone marrow for treating human diseases.

You should give a conclusion to your evaluation.

.....

.....

.....

.....

.....

.....

.....

.....

.....

.....

.....

(5)
(Total 5 marks)

Q7. The photographs show the flowers of two closely-related species of plant.

Species A Species B



Images: © iStock/Thinkstock

The drawings show chromosomes from one cell in the root of each plant during cell division.

Species A Species B



**One
chromosome**

**One
chromosome**

(a) The drawings show that each chromosome has two strands of genetic material.

(i) How does a chromosome become two strands?

.....
.....

(1)

(ii) Explain why each chromosome must become two strands before the cell divides.

.....
.....

.....
.....

(2)

(b) For sexual reproduction, the plants produce gametes.

(i) Name the type of cell division that produces gametes.

.....

(1)

(ii) How many chromosomes would there be in a gamete from each of these two plant species?

Species A **Species B**

(1)

(iii) It is possible for gametes from **Species A** to combine with gametes from **Species B** to produce healthy offspring plants. How many chromosomes would there be in each cell of one of the offspring

plants?

(1)

(c) (i) Look back at the information at the start of the question and the information from part (b).

What evidence from these two pieces of information supports the belief that **Species A** and **Species B** evolved from a common ancestor?

.....
.....
.....
.....

(2)

- (ii) For successful gamete production to take place, chromosomes that contain the same genes must pair up.

The drawings showing the chromosomes of **Species A** and of **Species B** are repeated below.

Species A Species B

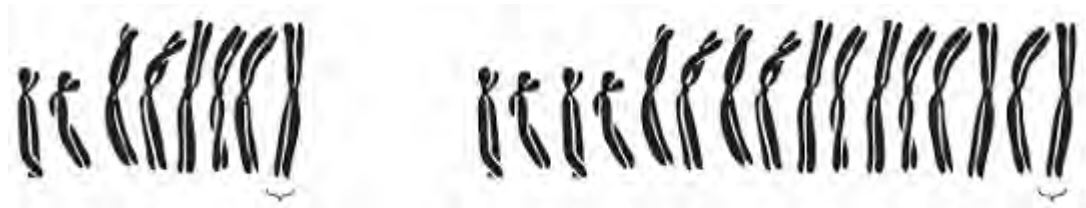

The offspring plants cannot reproduce sexually.

Suggest an explanation for this.

.....
.....
.....
.....
.....
.....

(2)
(Total 10 marks)

Q8. CADASIL is an inherited disorder caused by a dominant allele.

CADASIL leads to weakening of blood vessels in the brain.

The diagram shows the inheritance of CADASIL in one family.

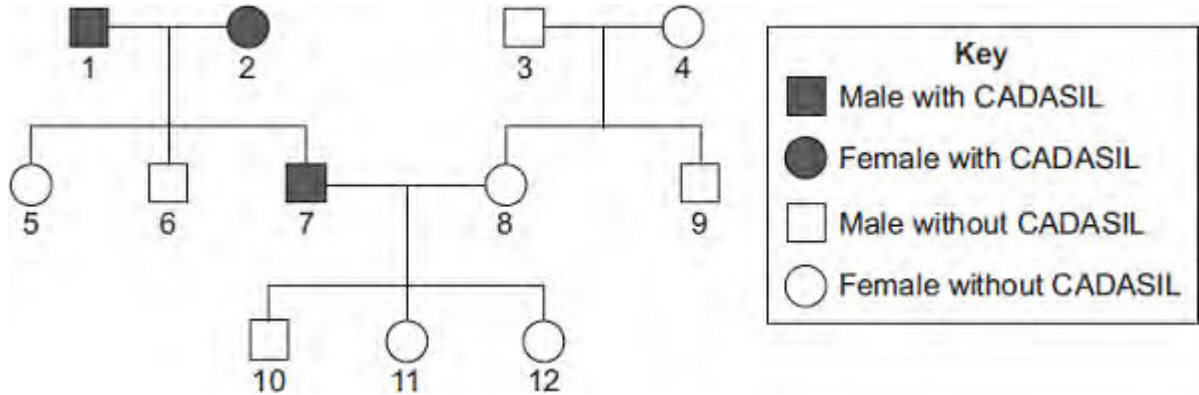

(a) CADASIL is caused by a *dominant allele*.

(i) What is a *dominant allele*?

.....

(1)

(ii) What is the evidence in the diagram that CADASIL is caused by a dominant allele?

.....

(1)

(iii) Person 7 has CADASIL.

Is person 7 homozygous or heterozygous for the CADASIL allele?

Give evidence for your answer from the diagram.

.....

(1)

- (b) Persons **7** and **8** are planning to have another baby.
Use a genetic diagram to find the probability that the new baby will develop into a person with CADASIL.

Use the following symbols to represent alleles.

D = allele for CADASIL

d = allele for not having CADASIL

Probability =

(4)

- (c) Scientists are trying to develop a treatment for CADASIL using stem cells.

Specially treated stem cells would be injected into the damaged part of the brain.

- (i) Why do the scientists use stem cells?

.....
.....
.....
.....

(2)

- (ii) Embryonic stem cells can be obtained by removing a few cells from a human embryo. In 2006, scientists in Japan discovered how to change adult skin cells into stem cells. Suggest **one** advantage of using stem cells from adult skin cells.

.....
.....

(1)

(Total 10 marks)